

DTU

Ram Pump Programme

Ram pump system design notes

Suitable areas for a ram pump system

Although all watercourses slope downwards to some degree, the gradient of many is so shallow that many kilometres of feed pipe or canal would be needed to obtain a fall of water large enough to power a ram pump. Ram pumps can be made to run with drive heads of less than one metre but they are not normally considered viable unless heads of two metres or more are available. If it would take a long length of feed pipe or canal to achieve this head, a ram pump system would be prohibitively expensive. The best geographical area for ram pumps is one which is hilly, with rapidly dropping watercourses and, ideally, springs.

In some areas of the world good regional records of rainfall and flow from springs and in watercourses are kept in government offices and libraries. In others, another agency may have carried out recent relevant studies. If any hydrological studies are available for the region in which you plan to install ram pump systems, you can save time, effort and costly mistakes by consulting the records and using their findings in your site design.

After potential sites have been identified, they must be surveyed. The survey yields information about site dimensions and the materials required to construct the site as well as, when more than one site is surveyed, yielding a cost and performance comparison.

Designing a good drive and pump layout is crucial to achieving good system performance and limiting the amount of maintenance required. The aim is to be able to achieve a large head of water between the drive tank and pump, while using a short drive pipe to connect them. The best and cheapest sites are those where the land falls rapidly, allowing all pipework to be short.

What to look for

Before arriving at a community to survey for a ram pump system, consult any available large-scale contour maps of the area. Look for places near to the community where streams cross contour lines and measure the distance along the stream between two contours. The average stream gradient can be obtained by dividing the height change between contours by this distance. An average gradient of at least 0.02 (0.02 or 2% is the same as 1 in 50) is needed for a water supply ram pump system. The pump will often be installed alongside rapids or a waterfall. If stream flow data for the area is available, look for seasonal variations, particularly during the dry months, and also for any data on the increase of flow during floods.

The section of stream shown in the map alongside falls quite rapidly. Where the contours are closest together on the stream's course, there is a drop of 20m over a distance of 200m, giving an average slope on that section of 10%. This site would be worth looking at.

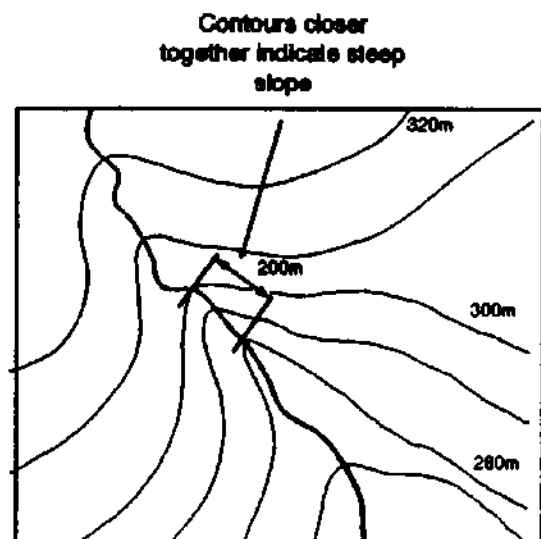

People living in a community are frequently the best source of reliable, up-to-date information about that particular area. The water in their area is vital to them, so ask them about local watercourses and sources, which ones they prefer to use, and which ones regularly dry up.

Sound is a good indicator of a drop in water. Where a watercourse is noisy and turbulent it will be dropping rapidly. It can save surveyors a lot of time to ask local people to show them places where the water is noisy, where it falls rapidly, and where there are rocks in the stream bed. Also ask to be shown any springs in the vicinity, particularly any with a source at the side of a valley along which a stream flows.

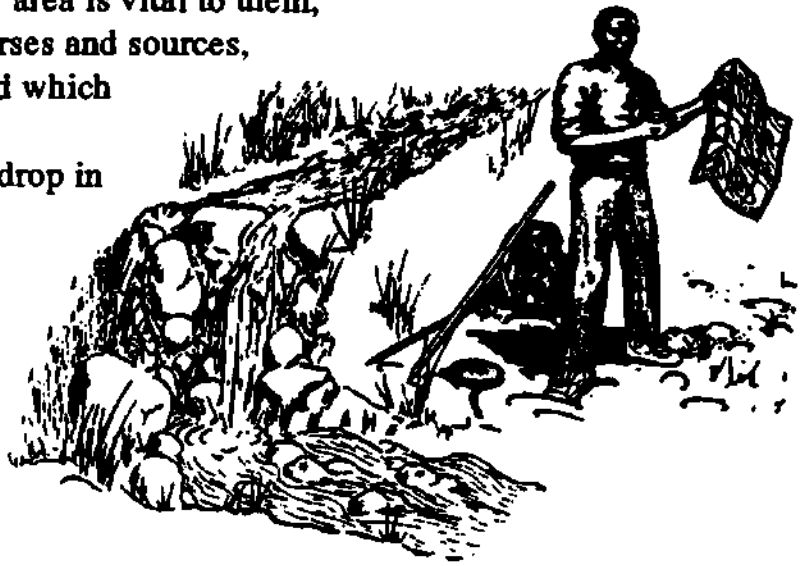

Allowing for floods

It is important to find out how the watercourse changes during a flood. Although spring-based systems are less susceptible to the extremes of flooding, it is still worth investigating and being aware of flooding as a potential problem when using a spring.

In very heavy rainfall, watercourses can swell to many times their normal flow within a short space of time.

Design of a drive system must take account of these worst weather conditions, even if they only last a few hours each year. Ask local people how far the water rises during a big flood and look for evidence such as deposited rocks and stream erosion on the banks to help to confirm their reports. Keep the pumps and as much of the drive system as possible above the maximum flood water level to avoid unnecessary damage.

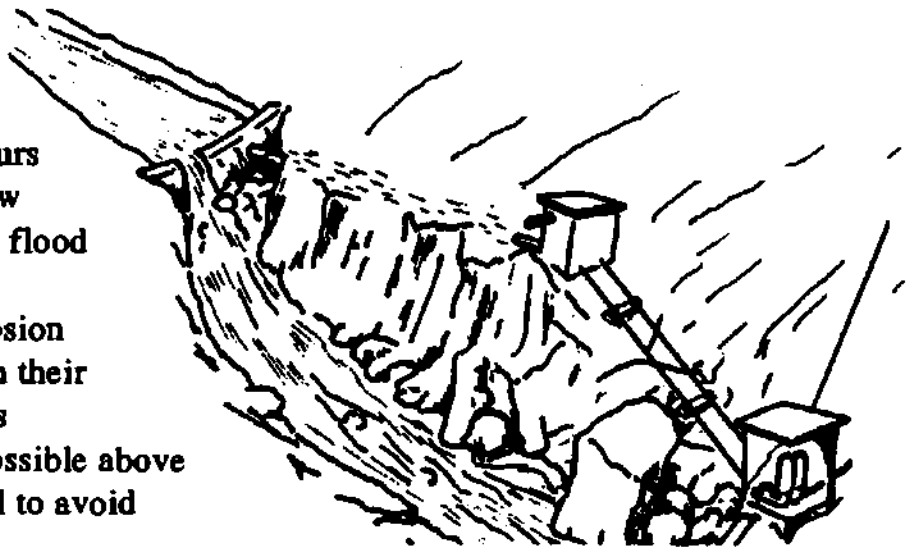

In the system sketched here, the main flow of flood water and debris is guided past the pumps by the large boulder or outcrop. Whilst the pumps may be submerged in a very high flood they will be protected from damage by most water-borne debris.

The one part of the system that will always be in the path of a flood is the dam or diversion structure. Bearing the expense in mind, this must either be built to withstand the worst flood conditions or built to be easily repairable. Some protection against the worst damage to a

dam should be included in the design, including a cage protection for the system intake, a floodwater overflow in the dam wall and boulders anchored into the stream bed above the dam to reduce the impetus of rolling stones.

Normally the pump(s) should be sited above floodwater level, but in some cases (particularly where the drive head available is marginal) this can be impractical. In these circumstances the pumps need to be sited so that they are protected from any debris in the flood, or so that they can be easily removed when a flood is expected.

Site surveying

Surveying should be in two stages, a preliminary assessment to locate potential sites, and a full survey to select the best option. In brief, the *preliminary survey* will involve the following:

- consulting any relevant maps and hydrology studies;
- travelling to potential sites to make a preliminary assessment and consult local people;
- selecting one or more sites with a high potential that will be surveyed fully.

The *full survey* of selected sites must be sufficiently detailed to provide all the information necessary for accurate system design.

The following information will be required:

Water source flow This figure must reflect the minimum flow of the water source in a normal year and so the measurements must be taken during the dry season. In order to ensure that the figure represents a typical minimum, local people should be consulted about the flow patterns over recent years. Some indication of maximum expected flows should also be obtained.

Drive head The maximum possible drive head of the site or the average angle of the slope below the water source should be measured.

Delivery head The height from the water source to the expected point of delivery should be measured. This will provide a rough estimate of delivery head but to be accurate the drive head should be added to this figure to give the actual delivery head.

Water requirement This should be estimated with reference to the population to be served (allowing for growth) or the area of land to be irrigated.

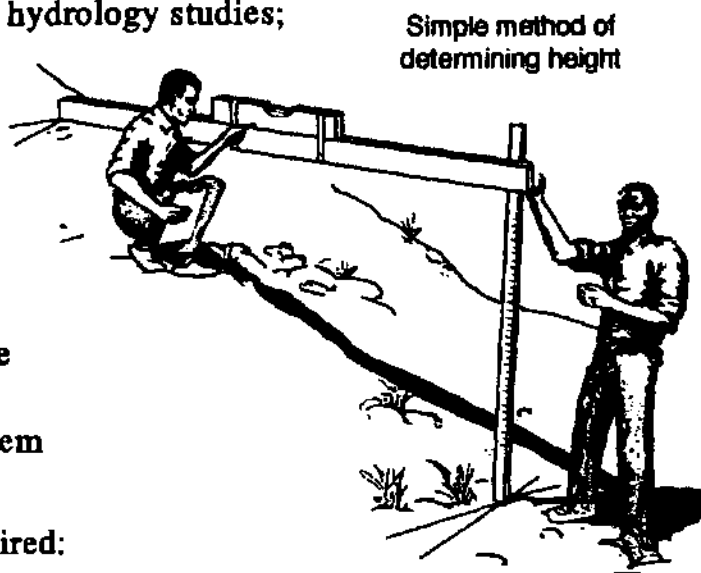

Pump selection

When selecting a ram pump there are often a number of decisions to be made concerning both its type and size. To make these decisions wisely, it is helpful to have some information about the site where the pump will be used. An estimation of the available drive flow and delivery head are needed, along with the anticipated delivery flow requirement. Knowing these will help to ensure that the correct pump is chosen.

The main decisions to be made are:

- whether to buy an imported pump or to manufacture one locally;
- the size and number of pumps to be used.

Pumps with drive pipes of between $\frac{3}{4}$ " and 4" are often commercially available or can be imported fairly quickly from manufacturers in Europe, N. America, etc. Larger models, with up to 12" drive pipes are also obtainable but usually have to be manufactured to order. Choosing between pumps from different manufacturers is not always straightforward. Comparisons of flow and efficiency can be made if the data is available. Cost, however, is normally very important, and varies considerably from pump to pump and manufacturer to manufacturer. The need to import spare parts and their cost should also be carefully considered. Where the source flow is large the choice is often between using one large pump or a number of smaller ones to meet the required delivery. Each model of ram pump with its recommended drive pipe will operate over a specified range of drive flows. In general, pumps are more efficient towards the lower limit of their drive flow, but produce a greater power output with large flows. A number of pumps can be used in parallel sharing a single drive tank and delivery pipe, but they must have separate drive pipes.

Using several small pumps rather than one large one can have the following advantages:

- each pump can be set for high efficiency;
- if the source flow falls below the required drive flow one pump can be stopped, allowing a reduced delivery flow to be maintained;
- a single pump can be stopped for maintenance work to be carried out without stopping all delivery flow;
- smaller sizes of pipe are often more readily available, whereas large steel pipe may have to be imported at high cost: it is also harder to work with large diameter pipe and to transport it;
- the maximum delivery head is generally higher on smaller pumps.

The cost of using a number of smaller pumps may be greater than using one large one but the benefits mentioned above need to be balanced against the extra cost.

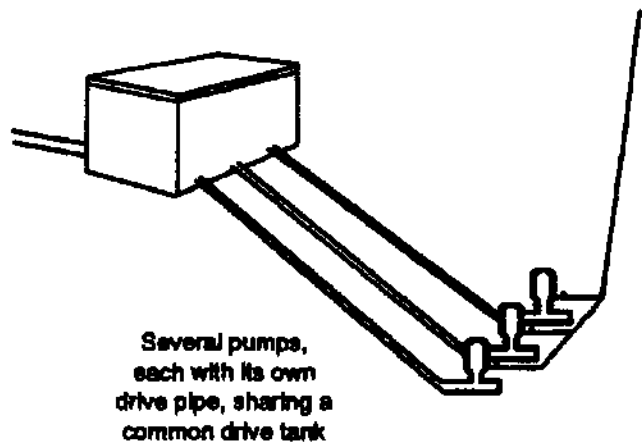

Intake design

The drive water for ram pump systems is normally drawn from a spring or a stream and diverted into a feed pipe. An intake structure is required at the chosen water source to collect the water and keep the feed pipe properly supplied.

Spring Intakes

When rain falls on high ground, some of the water soaks into the ground and seeps down through the permeable soil until it reaches an impermeable layer — usually clay or rock. The water collects on this layer, forming a water table of saturated material. The term water table refers to the upper level of the saturated material, and may rise and fall to reflect variations in rainfall throughout the year. As the level of the water table rises, the water spreads out until it reaches the side of the hill, then flows out as a spring.

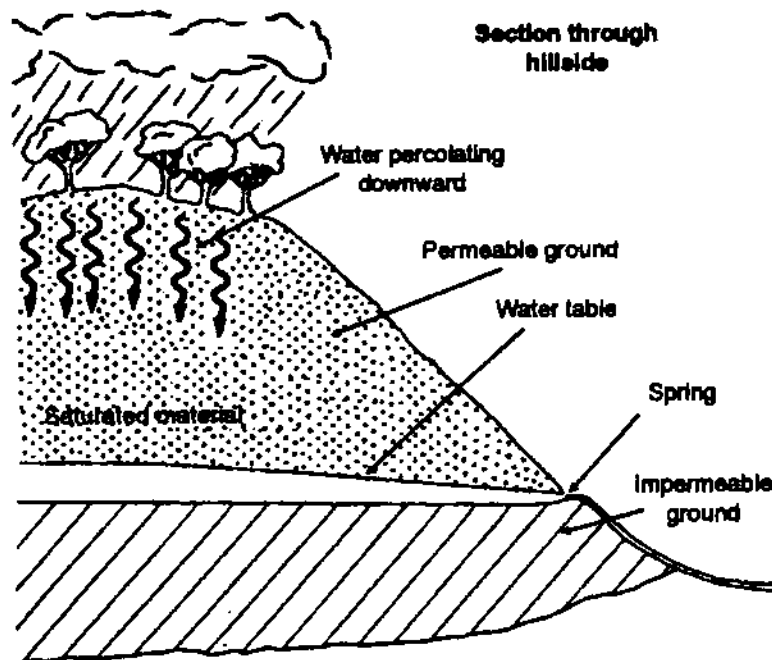

The nature of the permeable layer influences the kind of spring that occurs. If it is soft, sandy soil through which the water can travel easily, there may be many small springs as the water emerges all along the hillside. If the permeable layer is rock, with cracks through which the water sinks, there is usually one distinct spring.

In most situations water emerging from springs is completely pure and safe for drinking, whereas by the time it flows into a stream or river it has often become contaminated. This is why it is preferable for a ram pump system supplying drinking water to be served directly by a spring.

Spring flows are often quite low and in many cases it is necessary to combine the flow from several springs to obtain enough drive flow for a ram pump system. When this is done, the drive head available to the pump(s) is the drop from the lowest of the springs to the pump(s).

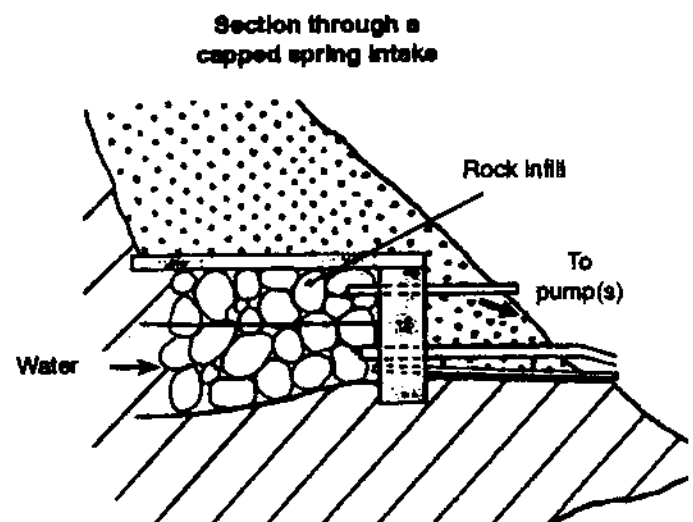

Seasonal variations in spring flow must be allowed for. In most cases the users require the same amount of water at all times through the year, so the system must be designed to use the amount of flow available when the springs are at their lowest. If this is not done, there may be times during the year when there is not enough water delivered, or when there is too little water to run the pump(s) at all.

Stream intakes — dams and weirs

On streams and small rivers the feed pipe must draw water from a relatively deep pool to ensure that the end of the pipe remains below water level. To achieve this it is usual to build an obstruction across the stream to raise its level, and to run the feed pipe through it. The obstruction can either be a dam with a specific overflow point (a spillway), or a weir where the water flows over it across its whole length.

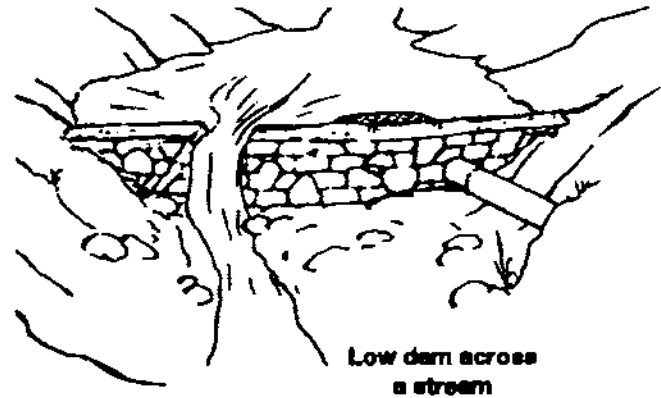

The types of dam or weir normally constructed are relatively small and simple as the increase in level needs only to be around 300mm. In situations where the drive head must be increased significantly in order to make a system viable, larger dams may be necessary. In many parts of the world, simple, cheap designs of dam have been developed that suit the local conditions and use readily available materials.

Siting the intake The best site for a dam or weir is where the gradient of the stream is large, such as just above an area of rapids or a waterfall. This enables a high drive head to be obtained within a small distance and so helps to reduce the length of feed and drive pipes. In situations where the gradient of the stream is fairly constant, constraints on siting other components of the system may determine the location of the intake. On streams with a low gradient there are two ways of obtaining a suitable drive head. One is to build a small, cheap dam some distance upstream and run a long and therefore expensive feed pipe to the drive tank. The other is to build a much taller, more expensive and complex dam and run a short length of feed pipe to the drive tank. Siting the dam in a narrow section of stream can greatly reduce the amount of material required in construction, particularly where a taller dam is to be built.

When choosing a site, careful attention must be given to the foundation on which the dam structure will be built. Solid rock foundations ensure a firm base but require the use of cement or concrete to attach the structure securely. If building on loose material, such as soil or gravel, it is necessary to dig a trench across the stream bed to provide a firm anchor for the structure. The foundation should extend well into the banks on either side of the stream, especially where these are soft.

The size of expected floods and the type of debris carried by the floodwater also affects the type and site of the intake structure. A low, well-anchored dam or weir can be designed to allow floodwater to pass straight over it so that, apart from the additional build-up of silt and other debris behind it, the structure is little affected by floods. Larger dams should be built strongly enough to withstand flows much higher than the normal operating levels expected. A spillway will normally take excess water over the dam, but can rarely be large enough to cope with floodwater levels. In some cases a bypass can be built for floodwater but care should be taken to prevent the stream from establishing a new course along the bypass route after the flood.

Components of an intake A number of features should be built into any dam or weir intake:

- Feed pipe socket — a socket built into the structure to enable the end of the feed pipe to be disconnected in case repair or cleaning is required;
- Screen — a coarse wire mesh covering the inlet of the feed pipe to prevent larger debris such as leaves and sticks from entering the system with the drive water;
- De-silting pipe — a small bore steel pipe built into the base of the dam or weir to allow periodic or continuous removal of silt from behind the structure. Silt must be removed before it reaches the level of the feed pipe and starts to enter the system.

Run-of-river intakes

Where the flow of a watercourse is too great to allow construction of a suitable dam or weir, an intake can be built into one of the banks. Such a run-of-river intake diverts a portion of the water from the main flow of the watercourse and channels it into the feed pipe. The intake must be positioned at a site where there is fairly deep water near to the bank. It is also necessary to design and site it so as to prevent excessive silting.

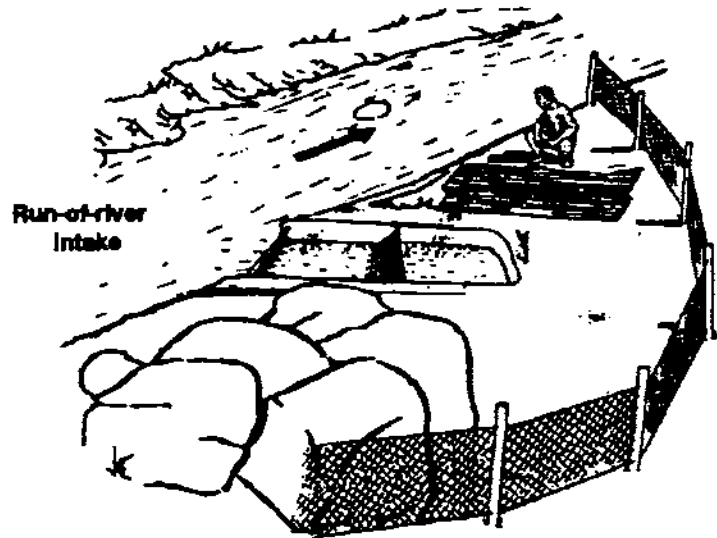

The spiralling flow of water on a bend tends to cause sedimentation on the inside of the curve, so intakes should never be sited in such a position. Siting an intake on the outside of a bend can be advantageous because the water tends to be deeper and silting reduced, but this position can leave it liable to damage by floating debris, especially during floods.

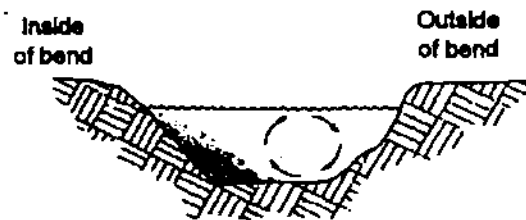

Section through river on a bend

Settling tank

Water, particularly in streams and rivers, can carry a large amount of small pieces of soil and sand — often referred to as silt. The amount of debris carried by water depends upon its velocity and the type of ground over which it has travelled. Silt can cause damage by eroding pipework and pumps as it is forced along by moving water, or by settling and building up to create blockages. When it is planned to use water that has a large silt content for a ram pump system, it is wise to include in the system a means of removing the worst of this debris.

When the velocity of flowing water is reduced, the particles of silt being carried tend to fall slowly and settle out. In some systems, the large pool of water behind a dam or in a spring box can slow down the water sufficiently to allow silt to settle out. A large drive tank will also reduce the velocity of the water sufficiently to allow some settling to occur.

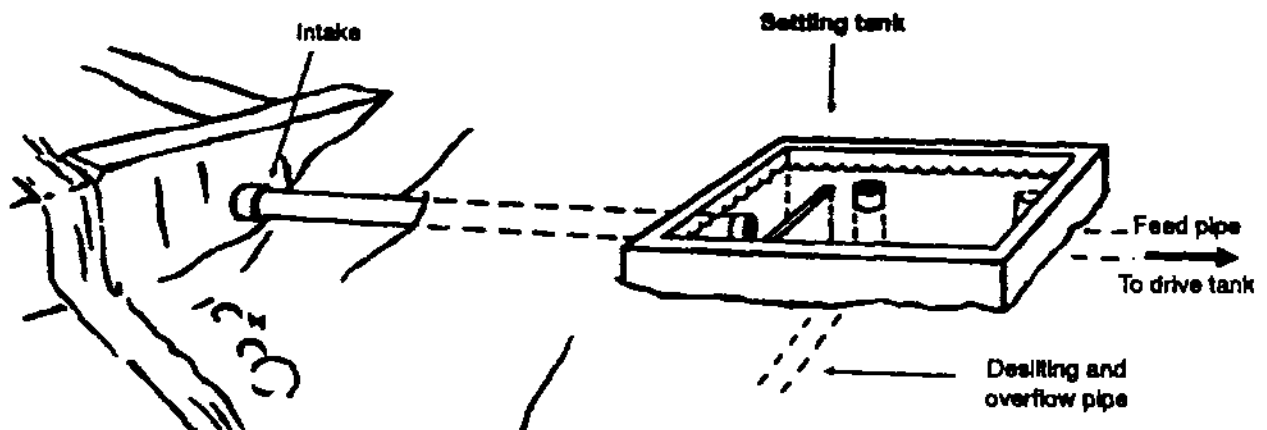

In situations where the source has a particularly high silt content and no large pool of water at the intake, a purpose-built settling tank should be included in the system. The settling tank should be designed to reduce the velocity of the water sufficiently to allow much of the silt to drop to the bottom of the tank rather than being carried with the water further into the feed pipe. The most convenient place to site a settling tank is near to the intake structure. If the system uses several springs, the settling tank can also be the most convenient place to combine the flows from each of the springs.

Settling tanks need regular maintenance. If they are well designed, a large amount of silt will collect very quickly and the tank will need cleaning.

A removable overflow that serves as a silt pipe installed as shown can make cleaning fairly simple. Withdrawing the overflow pipe from the elbow in the base of the tank causes a large flow down the silt pipe, removing settled debris from the base of the tank.

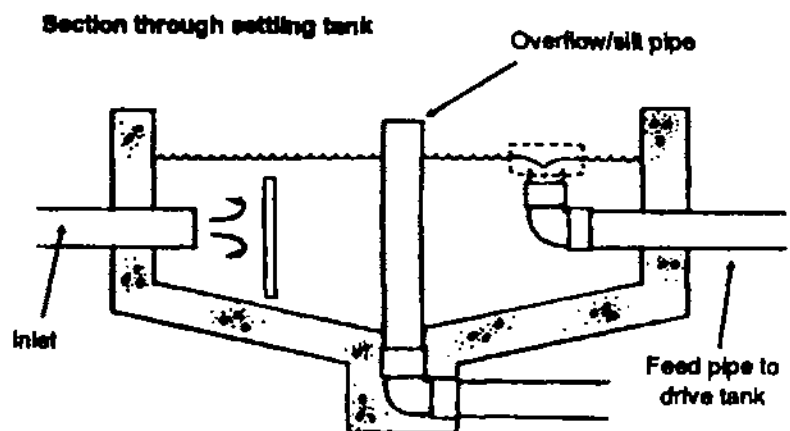

Drive system

The drive system is the part of a complete ram pump installation that receives water from the intake and feeds it to the pump(s).

It normally comprises three main items:

- a feed pipe that carries a constant flow of water from the intake to the drive tank;
- a drive tank that provides a store of water at the top of the drive pipe(s);
- the drive pipe(s) that supply water from the drive tank to the pump(s).

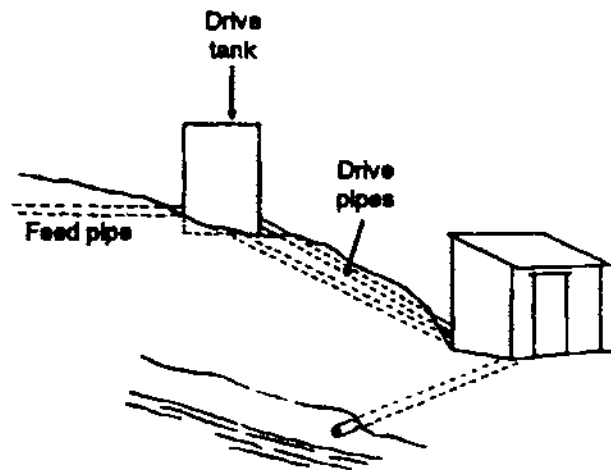

When first designing a drive system for a ram pump, all three items must be considered together because decisions involving any one of them will affect the design of the other two. In any particular situation there is a balance to be found between each of the items in the drive system. The balance involves the site layout and the relative costs of different types of pipe and of tank construction.

The system sketched below shows how the required drive head can be achieved in two different ways at the same site. Case A shows a small drive tank linked to the source by a short length of feed pipe. To reach the necessary drive head (H) a long drive pipe has to be installed to each pump.

The system sketched below shows how the required drive head can be achieved in two different ways at the same site. Case A shows a small drive tank linked to the source by a short length of feed pipe. To reach the necessary drive head (H) a long drive pipe has to be installed to each pump.

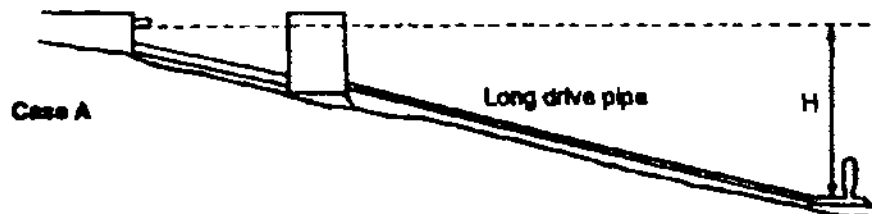

Case B uses a very tall drive tank being fed from the intake by a long feed pipe and supplying the pump through a much shorter drive pipe.

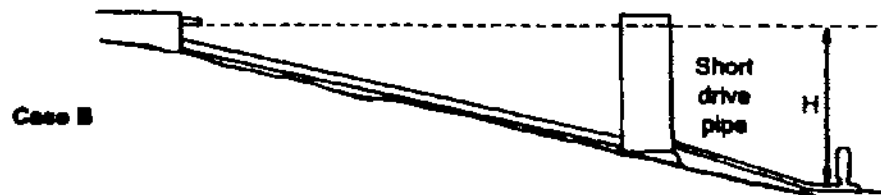

The final design choice in any situation will depend on the cost and the availability of materials and construction techniques.

Small drive tanks are generally cheap and simple to construct whereas tall ones require better foundations, reinforcing and more complicated construction techniques. On the other hand, galvanised steel drive pipe is usually far more expensive than low pressure plastic feed pipe and this cost constraint would often make Case B, using a long feed pipe with a short drive pipe, the more attractive option.

When designing a drive system it is best to look for an area below the proposed intake site which has a particularly steep slope. To obtain a certain drive head (H), the cheapest and most suitable site will be one that allows a small drive tank to be built at the top of a steep slope with a short drive pipe leading to the pump at the bottom as shown below. This will sometimes require a long feed pipe to carry water from the intake to the drive tank.

When using a spring or stream in a valley, the sides of the valley are often much steeper than the slope of the stream itself. Diverting the drive water in the feed pipe around the contour of the valley to a point where the side slopes more steeply (as shown below) can often enable the use of a small drive tank and relatively short drive pipe.

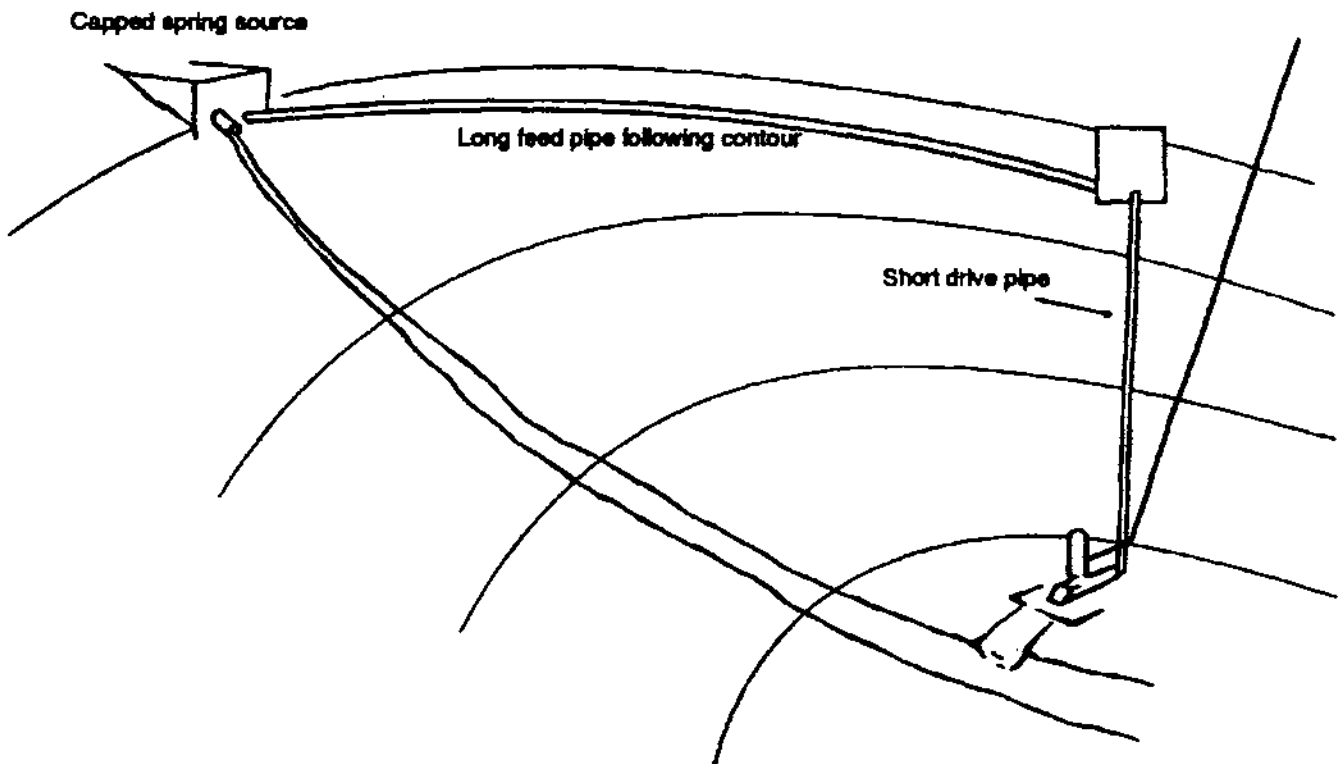
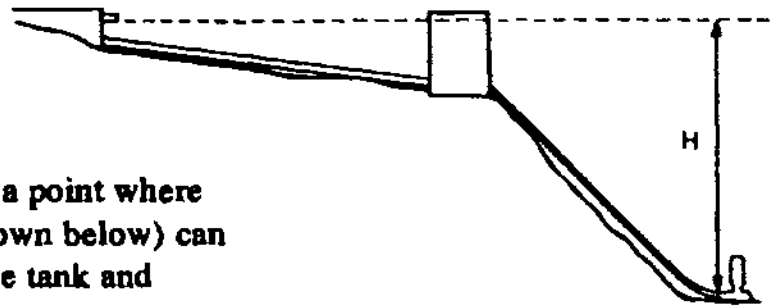

Feed pipe

The feed pipe carries a steady flow of water from the intake to the drive tank. It must supply sufficient water to feed all of the ram pumps running from the drive tank plus a small surplus that will overflow from the tank and ensure that a constant level is maintained inside. In small spring-based systems (or those using very small streams), all of the available source flow may be diverted into the feed pipe and the excess allowed to overflow from the drive tank. All feed pipes must be sized to carry enough water to supply all the pumps installed, plus an allowance for the overflow and any planned expansion of the system at a later date.

The pressure of the water in the feed pipe is generally very low, so cheap, low-pressure plastic pipe is usually adequate. If this type of pipe is used it should be buried or well covered in some way to protect it from damage by animals, farming, or strong sunlight.

The water flowing through the feed pipe will experience some friction against the pipe walls. This friction takes up some of the energy of the water and means that the water level in the drive tank under normal operating conditions will be lower than the level at the intake. This head loss caused by the friction of the flowing water must be taken into account when choosing the diameter of the feed pipe. In situations where there is plenty of drive head available a smaller and cheaper pipe size can be used. To achieve the required drive flow, the water in a small pipe will have to flow faster, with more friction and therefore a higher head loss, but when there is plenty of drive head available this will not matter. In situations where the drive head available is very limited, very little head loss in the pipe can be allowed and a larger diameter pipe through which the water flows relatively slowly should be used: the low velocity of the water in a large diameter pipe reduces the friction and therefore reduces the head loss.

Protecting pipe
by burial

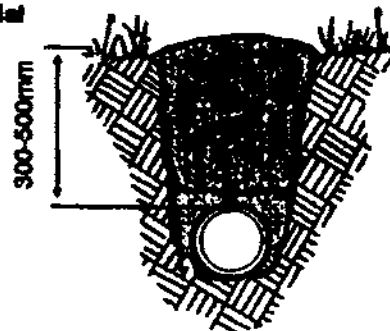

Drive tank

The drive tank is an important component in the operation of a ram pump system. It performs the following tasks:

- it keeps a steady water level, ensuring a regular supply to the pumps and a constant drive head;
- it provides a large body of water with an open surface that reflects the pressure waves travelling up the drive pipe when the pump is running;
- it also prevents air from being sucked into the drive pipe.

Very occasionally systems can be sited on a steep slope (more than 30 per cent) directly beneath the water source and can be designed without a drive tank. This can reduce the cost and complexity of the system but extra care must be taken in the design of the water catchment structure, which must then also perform the functions of a drive tank.

One common mistake when designing drive tanks is to have the entrance to the drive pipe too close to the surface of the water. In such cases air is drawn into the drive pipe

as the water accelerates down it. This can interrupt the operation of the pump and frequently leads to failure at the top of the drive pipe due to an effect called cavitation. It is recommended that the depth of water above the drive pipe inlet(s) be at least 500mm.

The volume of water in the drive tank, and in particular the cross-sectional area, must be large enough to maintain a steady level in the tank despite the intermittent outflow to the pump(s). As a rough guide, the cross-sectional area should be at least 20 times the total area of the drive pipes being supplied from it.

A number of types of drive tank can be considered. The choice between them depends both upon site conditions and the materials and skills available for their construction. From the authors' experience, three main types are useful, each with its own normal range of use.

- A A square or rectangular tank made from cement block or fired brick and plastered inside and out. The height of these tanks is usually not greater than 2.0m.
- B Large diameter PVC pipe set in a concrete base: restraining lines are recommended to ensure stability. These tanks are only appropriate for use in systems with small drive flows — particularly those systems that are spring-based. The height of these tanks is usually not greater than 6m.
- C Circular tank made of cement blocks with re-bar (reinforcing bar) running vertically and horizontally within it. The height of these tanks is usually between 2 and 4m.

Care must be taken to site the drive tank conveniently for operational reasons and to ensure that it is stable. A large tank full of water is very heavy and the foundations must be strong enough to support this weight without movement. Where possible tanks should be built on a solid rock foundation.

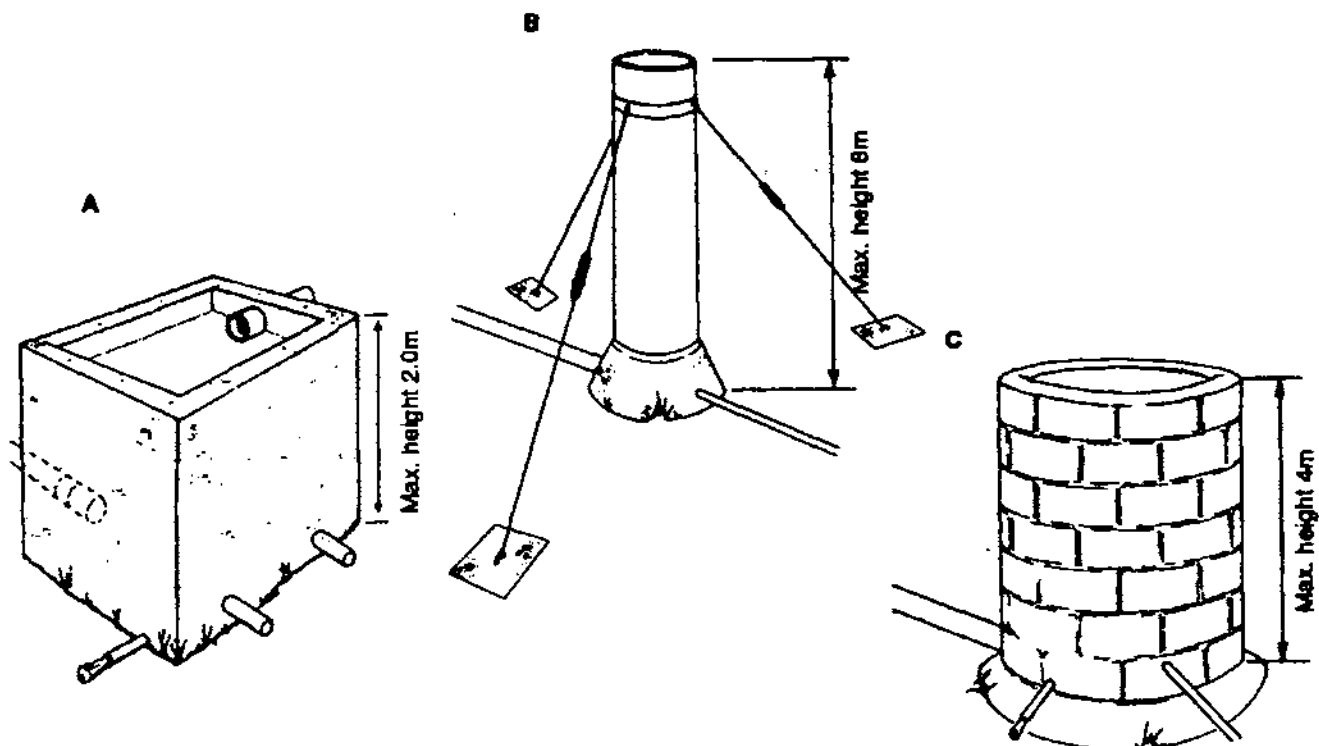

Drive pipes

Most pumps are designed for a particular diameter of drive pipe and this recommended size should be used under normal conditions, i.e. in the normal range of drive flows and pipe lengths. Selection of drive pipe diameter is a compromise between having a large diameter to reduce friction losses and a smaller diameter to give adequate water velocity. Never install a pump with a drive pipe diameter larger than the diameter of the drive pipe connection to the pump. Research has shown that many traditional pump designs actually underutilise their drive pipe capacity and so, where drive pipe lengths and drive flows are towards the lower limit of their range, the next standard size of drive pipe below that recommended can be installed. For example, the DTU M8 and M6 steel pumps are normally driven via a drive pipe in internal diameter 2" (50mm): for drive flows (not delivery flows) of less than 70-80 litres/minutes, a 1½" (38mm) drive pipe can be used instead. Despite its higher friction, the smaller diameter pipe will give better overall efficiency (and output) for the available drive flow because the velocity of the drive water through it is higher. This is especially so when the delivery head is towards the top of the pump's range. It is generally true of all ram pumps that at low flows and high heads reducing the drive pipe diameter leads to an increase in pump efficiency.

There are limits to the length of a drive pipe in a ram pump system. These limits can be calculated by reference to several theories that take account of such factors as the energy available to the pump, the friction in the system and the movement of pressure waves within the pipe. A complete explanation of the theory involved would be too complex to give here, so only some basic guidelines are described.

A short drive pipe, that is, one with a length less than about twice the drive head, will give a very high frequency of operation. This can reduce efficiency and will shorten the life of the pump. The advantage of keeping the drive pipe as short as possible is that its cost is reduced. As a general guide, it is recommended that the length of the drive pipe be kept to between two and four times the drive head, but should never be less than 6m. For example, a system with a drive head of 5m should be designed to keep the length of the drive pipe between 10 and 20m. Systems with drive pipes longer than about five times the drive head may not be able to operate at the optimum efficiency or peak output levels quoted by the manufacturer. Ram pumps with very long drive pipes will operate satisfactorily in many situations but are inefficient and unnecessarily expensive.

The angle of the drive pipe is not a critical factor and will normally be dictated by the particular site conditions. The manufacturer's recommendations for the correct angle for a drive pipe can be ignored provided that the guidelines for pipe length given above are followed. The drive pipe can have gentle bends along its length but it must be very firmly secured near to these points.

Section through simple drive pipe anchor

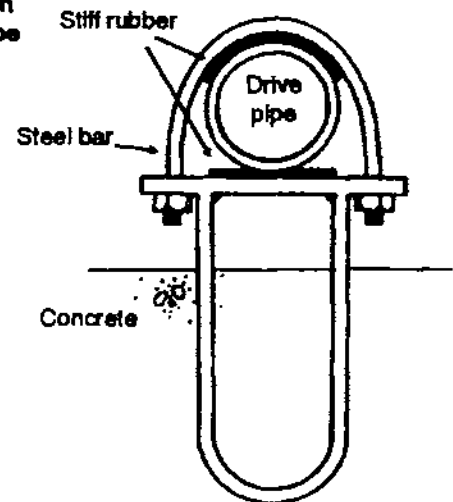

Drive pipes are normally made from galvanised steel pipe, which is the usually the cheapest and most readily available material with adequate strength and life. Well sealed, threaded joints can be used in most situations, provided that the pipe is properly anchored and cannot vibrate. In systems with very high delivery heads (over 100m), threaded drive pipe connections are sometimes inadequate. In these cases flanges should be welded to the ends of the lengths of drive pipe so that they can be bolted together. The same flanged connections should be used when the threads on the pipe are of poor quality, or when large diameter drive pipe is being used.

Pump

The pump itself should be considered as one component of the whole system. It needs to be carefully selected and sized in the same way as a tank or pipe, and its installation must be carried out carefully. The section on pump selection earlier in this pamphlet describes the process of choosing a ram pump or pumps to suit a particular set of conditions. After the particular requirements and constraints of an installation have been identified by the site survey, the pump(s) should be the first component to be selected. When the number and type of pump to be used is known, the sizing of tanks and pipes and the detailed design of the rest of the system can be carried out.

Pump base

It is essential that each pump be held rigidly to prevent it moving and vibrating with each pumping cycle. If a pump is not firmly secured, energy is lost as it moves and pipe joints will quickly break. The best way to secure a pump is to attach it firmly to a large concrete base. Some manufacturers recommend securing their pumps by setting bolts into the concrete but the difficulty of replacing these bolts when their threads rust or become damaged makes this unwise. A better method is to cast a steel frame, referred to as a pump cradle, into the concrete base.

There can be either a separate cradle for each pump or a single cradle to support them all. This can be made of angle-iron or other steel section welded together. The top of the cradle is left jutting out of the concrete and has holes pre-drilled through it so that the pump can be bolted down on it. If the securing bolts are damaged, they can be cut off and replaced without the need to recast the concrete base.

The shape of the cradle required will be different for each make of pump depending on the fixing methods incorporated by the manufacturer.

When designing a drive system, choose a suitable site for casting the pump base. The concrete base must be firmly anchored to prevent the continual vibration of the pump(s) damaging it, or separating the entire base from the material surrounding it. The site must also allow for drainage of the waste water from the pumps to prevent flooding around them.

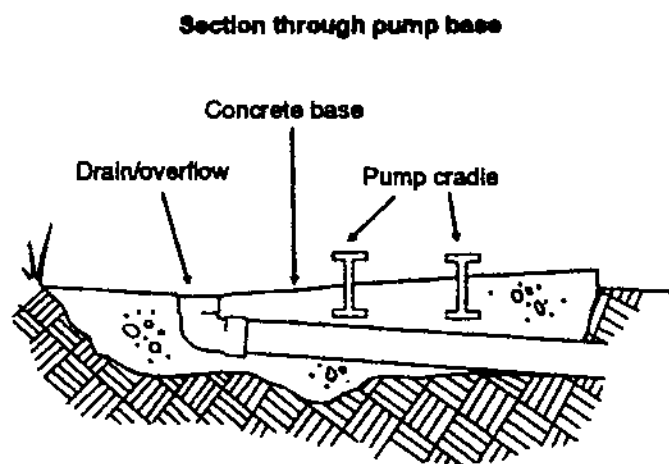

Pump house

A structure built around the pumps is not essential to the operation of a ram pump system. However, a pump house is recommended to provide security and protection. Curious children can easily damage a ram pump left operating in the open and it also makes an easy target for thieves. The pump house must be made large enough to allow complete access to all parts of the pumps for installation and maintenance. As a general guideline, allow at least 500mm between any part of the pump and the walls of the pump house or another pump.

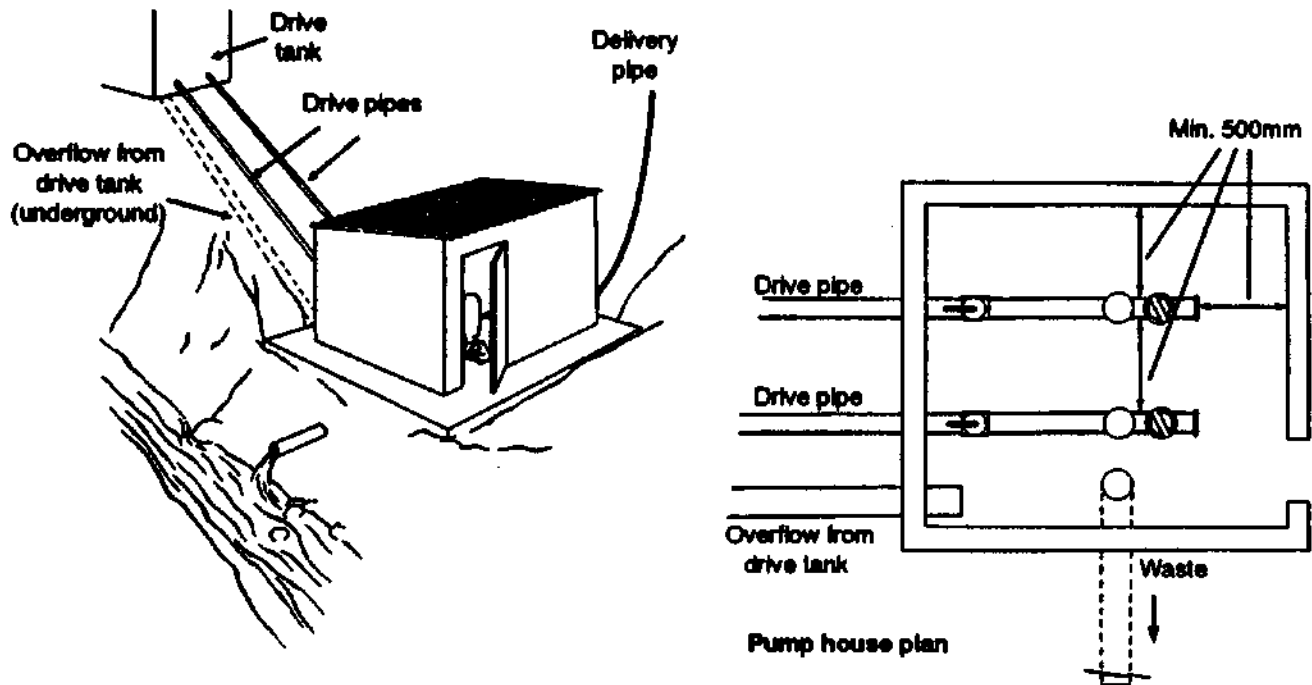

Delivery manifold

The delivery manifold connects the outlet from one or more ram pump's air vessels to the delivery pipe that carries the water to the point of use. It also traps air and collects silt.

Delivery pipe

The delivery pipe is an important part of any ram pump system and in many cases its length leads to it being the most expensive item. This is true despite the fact that, unlike drive pipes, many pumps can share the same delivery pipe. The delivery pipe must be sized to suit the expected delivery flow and the cost constraints. The larger the diameter of the delivery pipe, the more expensive it will be, but the lower the friction losses within it. Relatively cheap delivery pipe with a small diameter will impose high friction on the delivery flow, causing a high head loss. The pumps will have to overcome this head loss as well as lifting the water to the point of delivery. Choosing a diameter for the delivery pipe is therefore a balance between having a small diameter pipe to reduce costs or having a large diameter pipe to reduce head loss and maximise delivery flow.

As a rule of thumb, the calculated head loss in the pipe when it is carrying the predicted delivery flow should be between 5 per cent and 10 per cent of the delivery head.

Where there is plenty of delivery water available and low cost is important, a small

diameter delivery pipe can be used to reduce cost. If the expected delivery flow is only just sufficient for the users, a larger diameter pipe with a lower head loss should be chosen.

The route chosen for the delivery pipe should be as short as possible to reduce cost and head loss. However, the shortest route may not be technically feasible or necessarily the cheapest.

The sketch below shows a system with three possible delivery routes.

- Route A follows the lowest ground for much of its length: it is not recommended because a large section of the pipe is under high pressure and high pressure pipe tends to be more expensive;
- route B takes the most direct line but is not recommended because it has high points in which air would collect, causing air locks and reducing delivery flow;
- route C is the best route, rising quickly from the pump and then following a steady upward incline to the delivery tank. Only a short length of pipe is under high pressure and the line is fairly direct. A spur off the delivery pipe below the delivery tank should never be installed.

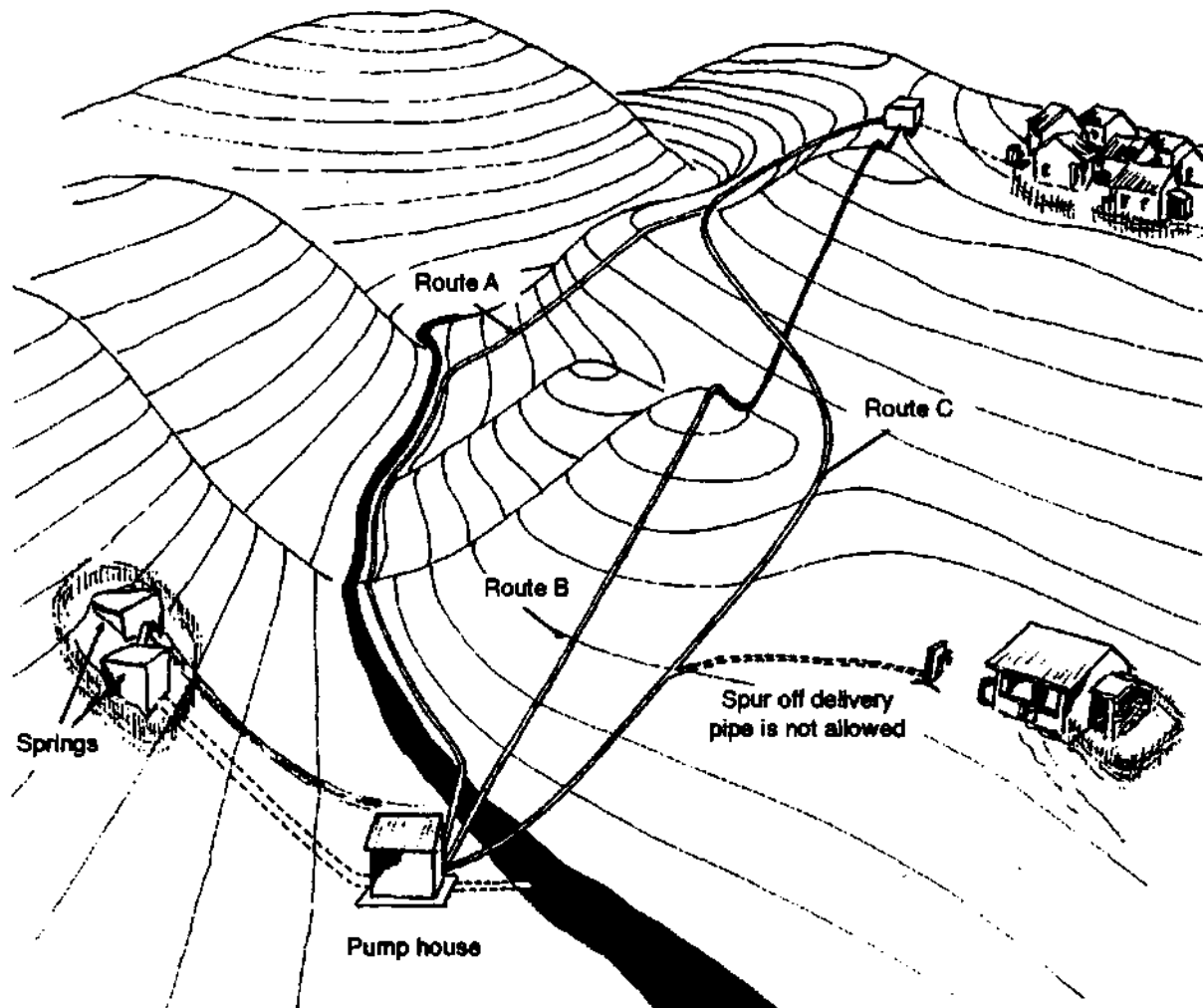

Distribution system

After installation and commissioning, most of the components of a ram pump system are forgotten by the users of the water supplied. The water is collected every day from stand pipes and it is the design of this distribution system that will be most relevant to them. It is particularly important to involve the whole community in the design of the distribution system and that the social organisation of water use is planned before construction.

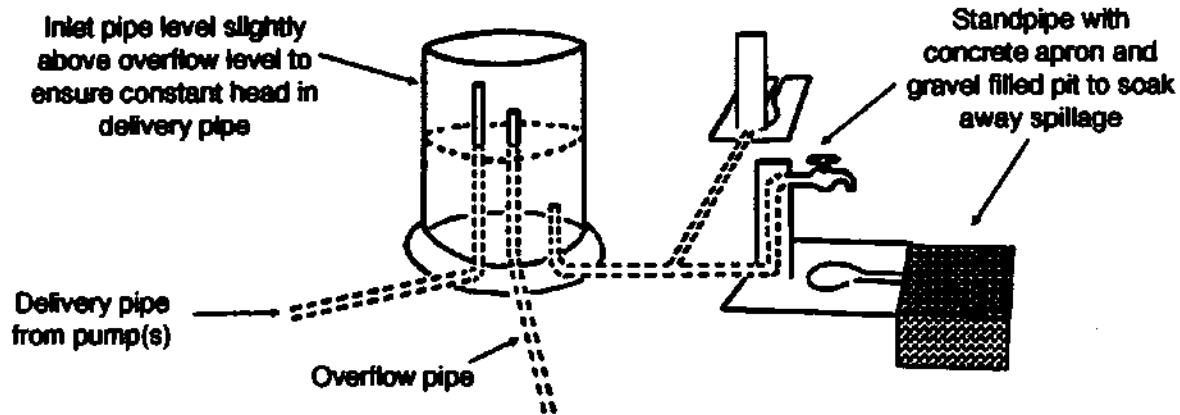

Most ram pump systems for domestic use will require a storage tank at the end of the delivery pipe. A ram pump operates for 24 hours each day, so the water pumped overnight must be stored for use during the times of peak demand. If there is to be more than one storage tank, the water should be pumped to the highest one and then fed by gravity down to the others. Alternatively, if valves are fitted on the inlets to each tank (except the highest one) the flows can be controlled so that all subsidiary tanks fill at the same rate. The total capacity of the delivery tank or tanks in the distribution system must be large enough to hold all of the water pumped overnight. They should therefore be sized to hold at least 12 hours supply and preferably 16 hours supply. The storage requirement can be calculated using the rule:

$$\begin{aligned}\text{Storage required in litres} &= \text{delivery flow in litres/minute} \times 60 \text{ minutes} \times 16 \text{ hours} \\ &= q \times 960\end{aligned}$$

Thus, for each litre per minute of delivery flow, provide about one cubic metre (= 1000 litres) of storage.

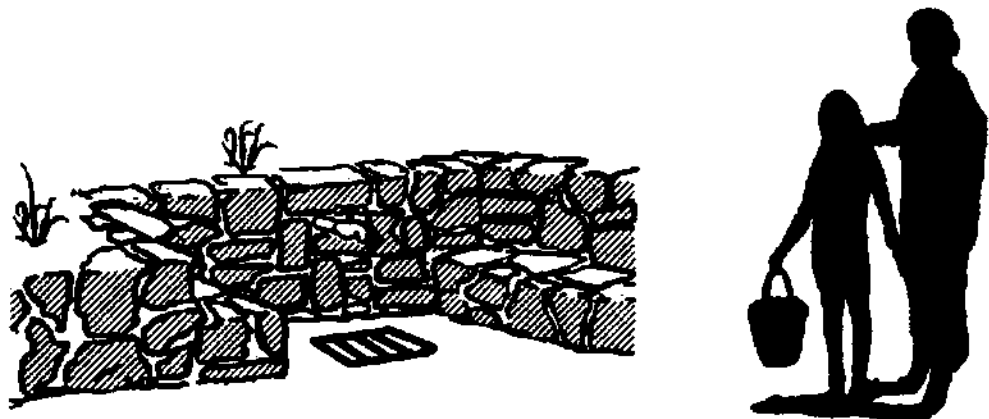

The delivery tank should either be conveniently situated for direct use or feed water into a distribution system. In many cases distribution can be directly through stand pipes connected to the delivery tank and fed by gravity. Larger systems serving bigger communities may require a number of distribution points each with a secondary storage tank and stand pipes. These tanks can either be assigned a priority — where the overflow from one tank feeds the next in a chain — or can be fed equally from the main delivery tank.

Single and multiple tank delivery systems

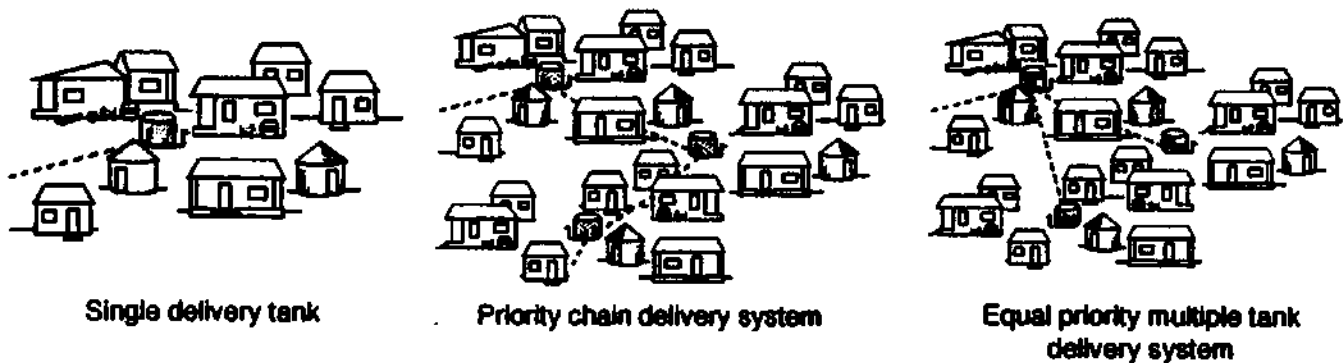

Water drawn from springs and high mountain streams is often very clean and can be used without any form of treatment. Where the water to be used in a ram pump system is drawn from a dirty source, filtration of the water delivered may be necessary. Simple sand filters when carefully installed and maintained can be very effective in improving water quality. The details of filter design and construction can be found in many publications and are beyond the scope of this book. From a system design point of view, however, it is worth noting that the delivery tank can itself be a filter tank as shown below. The delivery/filter tank feeds clean water to a second storage tank from which water is drawn for use. The top of the link pipe in the distribution tank should be a few centimetres higher than the level of the sand in the filter tank: this ensures that the sand never dries out.

Simple method of filtering delivered water

