

# What if the electricity GOES OFF?



By Michael Hackleman

**J**ust as everyone was getting ready to throw *the* party of the century and millennium—out with the old and in with the new—someone springs Y2K on us. Power outages, banking woes, communication breakdowns, and even economic collapse are some of the predictions I've heard. There is indeed a kind of convergence happening here. The changeover to the Euro-dollar is imminent. The satellites that make up the GPS (global positioning system) network will automatically reset to zero in late 1999. Things certainly look exciting for the turn of the century.

I guess you have to walk on the planet for more than 50 years, be in a war, have a wife and children, and fight a whole bunch of issues for a long time

to know that this feels familiar. The name changes, the date shifts, but it's the same question:

Are you ready?

People generally agree that something's going to happen, yet we don't yet know the nature of the beast. It has many faces. Earthquake, fire, flood, plague, meteor strike, nuclear attack, hurricane, and tornado—all strike in the moment. Economic collapse, crop failure, famine, and nuclear winter are forces of siege that could last months, years, or decades.

From a distance, the first evidence may be a blackout or a news report. The area affected by the disaster will dictate the probability, frequency, and durations of blackouts. If the scope of the disaster is large, other services—water, natural gas, gasoline, fuels, food, and goods—will fail.

Following that will be the loss of phones, police, fire, rescue, utility, Red Cross, and government services.

It is said that crisis has two components: danger and opportunity. There is danger in a crisis—catastrophe, collapse, and chaos. There is opportunity in crisis—restoration, renewal, and revival. Preparedness doesn't mean you'll survive, but it won't contribute to your demise.

There are issues that are specific to living in a city or in the country, so I will treat each as distinct scenarios. As you discover issues that approximate ones you may experience, you will likely be drawn to research these topics in more detail.

A blackout is a likely scenario in either a short-term or long-term crisis, so that is a good place to begin.

## Blackout ready

As winter storms roll in and you prepare for the effects of rain, wind, and cold, what plans can you make to handle an interruption of utility power? Most of us have experienced a blackout before. Has it been just an annoyance and inconvenience to you? Or was it disruptive to your life or business? There's not much anyone can do to prevent a utility blackout, but there are ways to mitigate its impact on your lifestyle whenever it does happen.

Is readiness for a blackout worthy of your consideration? Cost-cutting measures by utility companies throughout the USA have eliminated programs that protect utility lines from growing or falling trees. The new policy seems to be "fix it only if it's broken." Severe storms, then, will most certainly impact utility service. An interruption lasting one or more days is more real a possibility than ever.

The pressing question when a blackout occurs is: When will it end? Virtually anyone can put up with a few hours of interruption. Just break out the candles, don warmer clothes, and read a book or enjoy the company of a friend. The average blackout is a pop quiz. "Are you ready?" it asks. When the blackout continues, with no end in sight, the need for light, heat, water, and food grows.

## What's important in the home?

There are four critical loads in a home affected by a blackout: lighting, heating, refrigeration, and the water system. More specifically:

- **Lighting.** Lighting is essential for overall safety, particularly at night. Fortunately, it need not be electric. Candles, flashlights, and kerosene lanterns are traditional lighting sources for blackouts. Preparation for a blackout requires stockpiling matches, candles, batteries, or fuel for

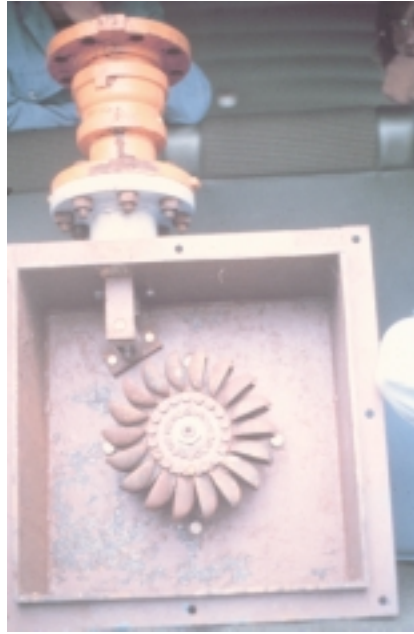

Even seasonal streams will supply power in the winter from units like this pelton wheel.

lanterns. Don't forget to put this stuff where you can find it in the dark!

- **Heating.** Central air heating systems, even if they use natural gas or propane, depend on electricity for the blower that will circulate the heated air. During a blackout, this system will not work. Areas with temperate climates allow most users to compensate with warmer clothing and the use of small propane or kerosene heaters. Wood stoves are also a popular alternative to central heating systems.

- **Refrigeration.** A refrigerator will keep things cool for a long time after power is interrupted. From the beginning, minimize the frequency and duration of opening its door to preserve its cool! As the blackout continues, consume the more perishable items first. Even a small stockpile of canned or freeze-dried foods will prove helpful during a blackout. Unless you've arranged for a way to heat and cook food, ensure that your supply is edible "as is," or with simple re-hydrating with water.

- **Water system.** Most community water systems are designed to work

for some time following a blackout, powered with huge standby generators. Private water systems built around streams, springs, and wells that use electric pumps will quit working as soon as the electricity goes off. The pressure tank will still deliver some water, so immediately fill handy containers (bottles, buckets, bowls, bathtub, etc.) before this supply is depleted. The standard household water heater is another source of 30-50 gallons of water. How will you handle toilet, shower, and sink during a blackout? Some forethought and planning will help with these processes during an extended blackout.

## Other sources of electricity

Utility electricity available at the wall socket in a home or business is rated 120 Volts and 60-cycle AC. There are two ways to supply this same specialized power in a blackout: a standby generator and a battery-powered inverter.

The standby generator:

Where the interruption of utility power even for a few hours is critical—i.e., emergency equipment and services in businesses and hospitals—a standby generator may be used to supply power. A standby generator is an engine combined with a generator. This unit may be started manually or automatically and requires only fuel (gasoline, diesel, or propane) to operate until grid power is restored.

Homes may also use a standby generator to supply electricity during a blackout. A common arrangement is to start the backup generator from a remote control panel in the house. Some or all of the household circuitry is transferred from the utility line to the standby generator. This process is reversed when utility service is restored.

A standby generator for homes, businesses, or hospitals is usually



Dual meters are common when renewable energy systems put power back down the utility line.

rated to handle only some of the existing loads. A generator large enough to handle *all* of the loads is big and expensive to buy, maintain, and operate. A detailed analysis of existing loads should precede the installation of any standby generator. Make a load list. This is a good place to rate loads as essential or non-essential. Later, this helps identify circuits that will be left ON or shut OFF during generator operation.

In theory, the standby generator seems like the best way to handle blackouts. However, there are five reasons why it is less than an ideal solution: expense, fuel supply, peripherals, efficiency, and sound.

- It is a fairly expensive system for only occasional use. For a big chunk of time, the generator is not doing anything for you at all. Standby generators designed for long life and minimal noise are more expensive than ones operating at higher rpm (3600 rpm).

- Requires fuel to run. Either you must install a large fuel tank nearby or you'll be transporting fuel cans to and from town to feed a rather thirsty beast. Weather severe enough to require generator operation is rarely the best time to travel to refill empty gas cans.

- Needs peripheral hardware to work. Remote startup. Transfer switch. Monitoring gauges. Fuel supply. A firesafe, weatherproof installation (shed?). A battery that is ready to start the generator. Add these costs to that of the generator itself.

- It is needed for even small loads. A generator powering a few loads has a much lighter load, but gobbles (inefficiently) fuel as though it's doing more work than it is. Either way, it experiences wear.

- It is noisy. This is a security issue. A standby generator lets everyone in the area know where you are. At the same time, proximity to the generator impairs one's own hearing. Bad combination.

Despite these limitations, standby generators have their place. There is 100 times more available energy stored in a pound of gasoline than a pound of battery. In the short term and for big loads, the generator gives the biggest bang for the buck. The questions are: how big is your need and what's the duration of the blackout?

#### The battery-powered inverter:

Another way to make electricity like that supplied by a utility is through an inverter. An inverter is an electronic device that converts DC electricity

into AC electricity. (DC is direct current. AC is alternating current.) The result is identical to the stuff from the utilities, even cleaner.

One source of DC electricity is a battery. Thus, an inverter can transform the DC electricity from a battery into 120V, 60-cycle AC power. A battery is not truly a source of electricity. Rather, it is a means of storing the energy (in a chemical form) of the DC electricity supplied to it. The best sources of DC electricity are PV (Photo-Voltaic, or solar) modules, wind-electric machines, and small hydro-electric systems. More on this later.

A battery charger plugged into the utility line will also supply DC electricity to a battery. This is a popular idea. The batteries are charged and maintained at full readiness, and ready to substitute their energy for that of the utility for as long as they're able. The bigger the battery (bank of batteries), the longer the system can bridge the blackout.

These systems are common. Have you ever wondered why your phone works when a blackout occurs? Phones run on electricity, too. The phone company has a "standby" or backup system which switches ON automatically when utility power is interrupted. This is called an uninterruptible power system, or UPS. At the heart of the UPS system is a bank of batteries that are much like the battery in your car, except bigger and heavier. Those batteries store enough energy to run an entire complex of telephone-related equipment for many hours during a blackout. When a blackout lasts longer than that, an engine-driven generator (fueled by gasoline, diesel, or propane) is started up to handle the entire load and recharge the batteries.

Until a few years ago, a small UPS system was the primary way to avoid the loss of power to a computer during a blackout. A critical period is the time it takes to switch between utility and battery power. To avoid any glitch, early UPS systems would run

the computer's inverter from the batteries full time, while utility electricity only maintained the battery pack's charge. Better electronics have improved the purity and speed of the transition time. Today, many computers are unaffected by the transition as newer "line-tie" inverters switch from utility to battery, or back, in milliseconds.

There are many applications where a split-second transition between utility and battery power is not an issue. Or where more modest loads are dictated. Here, a simple and less expensive system—a small inverter, battery, and transfer switch—works well. The system I installed when I lived in the city was sized to power a furnace blower (and its controls), refrigerator, stereo, and four lights during an emergency. The system was installed near the main distribution box (where the fuses or breakers are located). It involved moving the wires and breakers (to which the wires are connected) into a service box I added. With a transfer switch added between the two boxes, I could shift these three circuits between utility power or the inverter's output. This is basic electrical wiring, easy for a DIY (Do-It-Yourself) homeowner or a local electrician.

How did it work? I'd give the blackout 10 minutes before I looked for the load list. It's a map that lets me move about the house, shutting off unneeded loads on the few circuits that will be switched to the inverter. (The energy stored in the battery is the lifeblood of the backup system. Don't let it bleed away needlessly!) Next, I'd shut off the main utility switch, flip the transfer switch to inverter, and turn the inverter ON.

## A home UPS system

The simplest backup system is composed of two major components—a battery and an inverter. Batteries and inverters come in all shapes and sizes. Select carefully and they will serve you well.

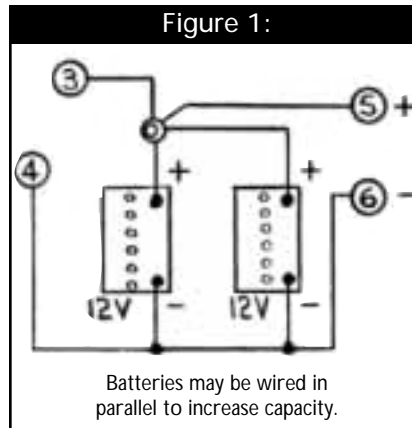

The important characteristics of a battery are voltage (V), capacity (Ah), and design cycle.

**1. Voltage.** Common battery voltages are 6-Volt and 12-volt (hereafter, 6V and 12V). Large battery banks will employ individual 2V cells with massive capacities.

**2. Battery capacity.** Battery capacity is rated in Ah (Amp-hours) or cold-cranking amps (useless for our purposes). The Ah rating is helpful in describing the amount of energy the battery can hold.

**3. Design cycle.** Batteries are of two types: SLI and deep cycle. (A cycle is a discharge and full recharge.) A SLI (starting-lighting-ignition) battery is used in a car to start the engine—a fairly shallow cycle—and is immediately recharged by the engine's generator. Deep cycle batteries are used in applications where the battery's energy may be nearly depleted—a deep

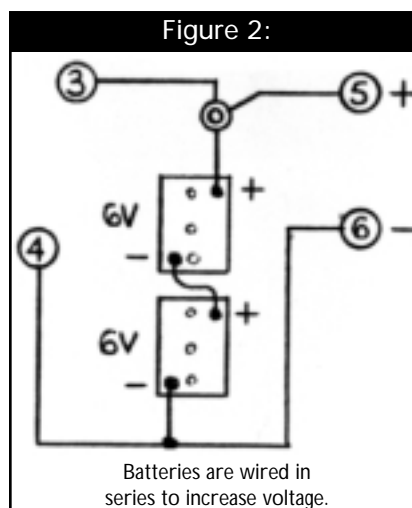

cycle—in use. This process will damage a SLI battery internally and eventually result in its failure.

## 12V vs 6V batteries

The smallest deep-cycle battery you might use for an inverter is rated 12V and 110Ah. These are used in boats, trolling motors, and RVs. At 50-70 pounds, this battery is about as much as a healthy person can carry and maneuver in a confined space. To increase the capacity of this system, you "parallel" a second battery with the first (Fig. 1). To parallel a battery (same voltage only, please!), make connections positive-to-positive and negative-to-negative for both batteries and load. The voltage will stay the same; in this case, 12V. At any time later, you can increase the system's capacity (the rate or duration of power delivery) by adding batteries of the same voltage, even if they have different capacities.

A better building block in a battery bank for inverter operation is the 6V, 220Ah battery used in golf cars. It has half the voltage, yet twice the Ah of a 12V battery of the same size and weight. So, they have the same "energy density."

To supply the 12V electricity our inverter needs, two 6V batteries are connected in series (Fig. 2) like dry cells in a flashlight, with ONE wire connecting the positive of one battery to the negative of the other. (A novice may try to connect the other two posts together, which results in a very hazardous short-circuit.) The result of the series wiring is a new, bigger battery of 12V with the remaining posts, positive and negative, connected to the system in the same way as would be any 12V battery.

Theoretically, pound for pound, two 12V batteries in parallel will equal the capacity of two 6V batteries in series. In reality, a 6V battery is tougher—thicker plates, fewer cells to water, and greater tolerance to deep cycling and cold weather—than a 12V battery,



resulting in a longer service life for almost any application.

Expect to pay \$70-85 for a 6V, deep-cycle golf car battery (or equivalent). You'll need them in pairs for inverter operation at 12V.

## Inverter features and ratings

Today's inverters serve two critical functions. First and primary, they convert the battery's output (low-voltage DC) to a form that your household can use (120 or 240 volts AC, 60 cycles). Second—and most desirable for standby generator or utility interaction—is the internal battery charger option. A battery charger's operation (DC-to-AC) is simply the reverse of an inverter's operation (AC-to-DC). When combined in one box, the inverter and battery charger share (use) the same electronic hardware. In this way, utility electricity stores itself in a battery which, in a blackout, will release the energy, powering an inverter to make 120V, 60-cycle AC.

The battery and inverter must be "matched" to each other and to the loads you expect them to power. Appliances, lights, and tools are referred to as "loads." Each "load" has its own power (consumption) rating. You may have heard the term "wattage." This is an expression of the RATE at which a load uses electricity. Generally, lights and radios are small loads while refrigerators, motors, and toasters are big loads. The effect of loads is accumulative. That is, if you operate more than one load at one time, the total load is the addition of all those wattages. The power consumed by even one small light all night might be greater than that of a toaster operating for a few minutes.

In an emergency, you must reduce the loads the battery/inverter unit will power. The faster you use the energy stored in the batteries, the sooner you'll have a "second" blackout! Make sense? In a blackout, you



A solar-powered food dehydrator lessens the need for refrigeration.

become the power company, responsible for rationing both the rate and quantity of expected household needs for a specific time period.

Inverters have voltage and wattage ratings.

**1. Voltage.** The voltage ratings are divided into input and output. The input voltage is the DC voltage of the battery bank. Inverters exist to handle DC voltages of 12V, 24V, 32V, 48V, or 120V.

The output voltage of the inverter is the 60-cycle AC voltage. It may be 120V (commercial) or 220V (industrial), or both.

**2. Wattage.** Wattage ratings of inverters range from 50-4,000 Watts (4kW) or larger. What wattage works for you? Here's a handy rule-of-thumb.

a. The *minimum* wattage rating of the inverter is determined by the largest single load you expect it to power.

b. The *maximum* wattage rating of the inverter is the largest combination of loads you want it to power simultaneously.

For example, if you had loads of 50 watts, 120 watts, 220 watts, 1200 watts, and 1400 watts, the inverter rating could be as low as 1400 watts (for the biggest single load) or as high as 2940 watts (for *all* of these loads.)

High-power inverters are expensive and require more battery capacity. Smart owners balance this situation by avoiding simultaneous use of heavy loads. In this example, then, selecting a 2000-watt inverter would handle everything else if the operator avoids using the two biggest loads simultaneously.

The price tag of a small UPS system is well within the reach of many homeowners. Inverters average a dollar a watt and batteries (lead-acid type) about a dollar a pound. A battery/inverter system is virtually maintenance-free and tucks away on a shelf in the garage or carport, ready to work when the blackout comes. Fortunately, your investment in this system has a second success. It is the core of a system that enables you, when you're ready and able, to tap the renewable energy sources—solar, wind, and hydro—all around you.

## A no-inverter DC system

Utility power, in the form of 120VAC, 60Hz, is very specialized power. In a blackout, you may have less need for it than you might think. It is well known that a car or truck is useful in emergencies for the radio, light, heat, and shelter it offers. Without the engine running, there is enough capacity in vehicle's 12V battery to power lights, radio, and the horn for some time. Periodic engine startup adds heat to the equation and recharges the battery, too!

Similarly, a stand-alone 12V battery pack located in the garage or home may be kept on charge (with a battery charger) until utility power fails and its stored energy is needed "as is," at 12V. This does not mean that you can power the same 120V loads as an

inverter will. The RV (recreational vehicle), automotive, and marine markets offer almost any type of appliance, motor, tool, pump, and light that will work directly from 12 volts DC. For example, several high-efficiency 12V fluorescent lights will provide 20-40 hours of welcome light from one automotive-size battery. I can think of nothing more reassuring in the darkness, particularly when a storm is raging, than the steady glow of a lamp.

How do you wire up a 12V system to be blackout-ready? For occasional use, clamp-type lamps and several lengths of extension cords may be connected together to distribute light through a dwelling. This assembly can be coiled up and put away until a blackout occurs. A more permanent solution is to dedicate an electric circuit to 12V use. Existing household circuitry rarely adapts easily to a dedicated usage (unless one is still building one's home). Here, a well-planned layout and one standard roll of Romex wire will add a 12V circuit to any home, shop, or building for lights and a radio.



Solar cookers achieve 250-350 degrees during operation.

## Living beyond the grid

Most RE (renewable energy) systems are based around 6V and 12V storage batteries. The simplest RE systems use a solar module, one or two batteries, a few 12V lights, and a 12V radio. Except for the PV module, this is identical to the system

(described above) to supply power during a blackout. Becoming blackout-ready, then, is a step in the direction of becoming energy-independent.

RE systems are generally located "beyond the grid." The cost of bringing in utility service even a mile is often more expensive than investing in a system that is utility-free. RE technology has focused on being modular. This makes it simple to add more capacity, and to move and re-install the system.

There are energy sources other than PV modules worthy of your attention: wind and water. Wind-electric machines and small hydro-electric turbines are also viable energy producers. A multi-source system is smart for three reasons:

1. Seasonally, wind and water sources of energy are complementary with solar-generated power.

2. Solar, wind, and water system hardware is designed to supply low-voltage DC, particularly 12V and 24V.

3. A system designed around one source readily accommodates additional sources. The systems are more similar than different. Therefore, the battery bank, distribution and fusing panels, and monitoring equipment are

Figure 3:

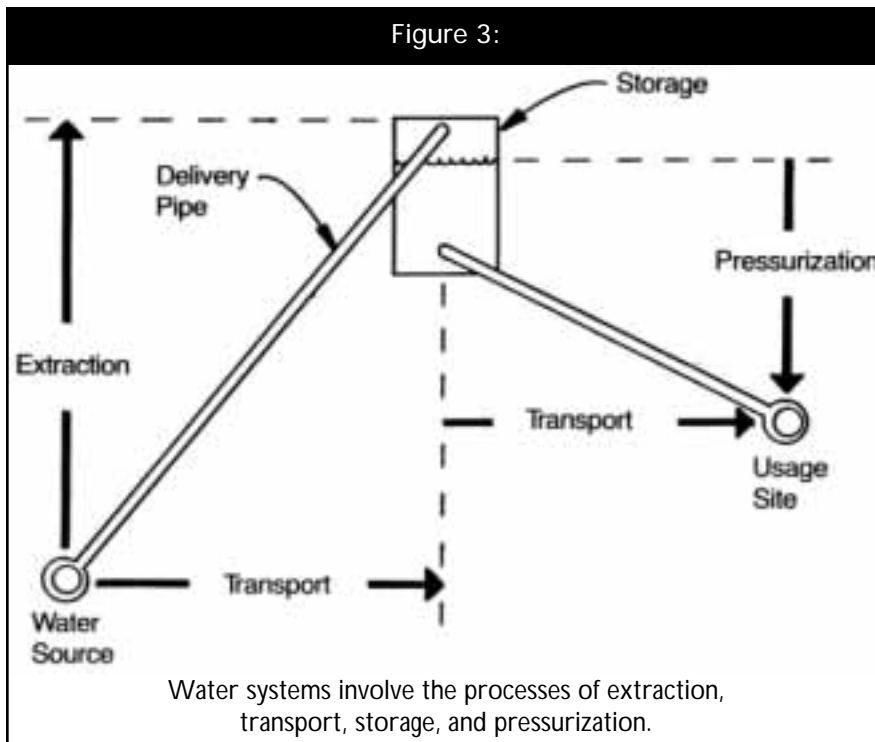
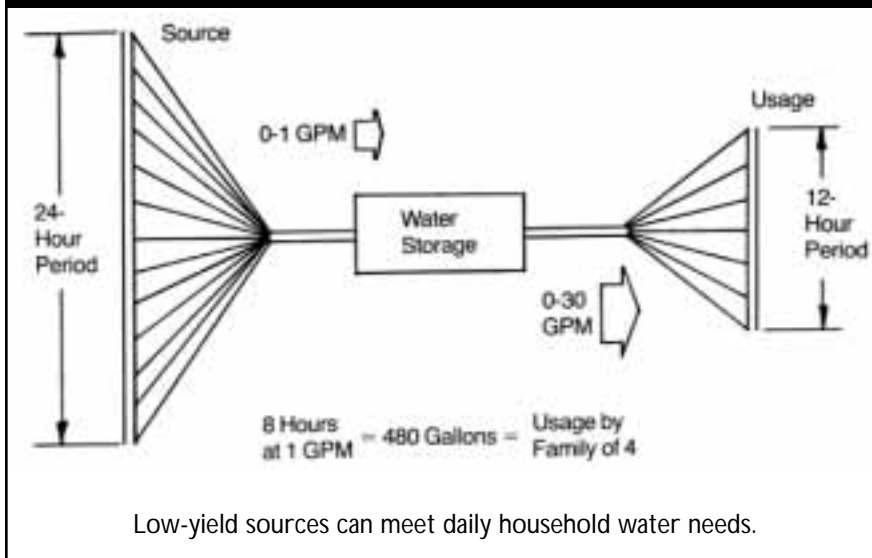

Figure 4:



virtually the same and are shared by the different sources.

Putting together a backup or RE system is also a good way to learn the basics of electricity itself (i.e., volts, amps, watts, and amp-hours). I believe this is essential if one is going to rely on electricity for anything. With this knowledge comes an appreciation for how energy moves and changes, and how it can be harnessed to fill your needs.

## Beyond a blackout

Preparing for something worse or longer than a normal blackout is a frightening prospect. I avoid being overwhelmed by the sheer immensity of the topic by dividing the issues into two phases: basics and preparation.

### Basics:

Basics represent the checklist of life. What does a human being need to survive, short and long term? Air, water, shelter, and food.

**Air:** Few think much about breathing until they can't. Remedies that take longer than three minutes are of little value. Shelters must remain tied to the atmosphere directly. If there are airborne pollutants (smoke, ash, etc.),

filters will be needed to breathe without risk of injury.

**Water:** Humans can live only three days without water. See that you store some or have access to it. Water is easily contaminated. Figure out a way

to purify it. Drink and cook with pure water or risk illness.

**Shelter:** Human beings are amazingly manipulative of their environment, yet remain vulnerable to it in crisis. Shelter holds back the extremes of heat and cold, offers dryness, and feels safer for sleeping.

**Energy:** While we manipulate energy in our home, workplace, and car on many levels every day, it is all artificially generated. When that source is lost, the first job is to conserve it, in whatever form it is available. With any prolonged interruption of transportation or utility services in crisis, stockpiles of fuels like gasoline, diesel, and kerosene will be depleted or prohibitively expensive.

**Food:** Humans can live about a week without food, less in cold weather and limited water. In a mild emergency, stockpiling food, even enough for 5-7 days, saves having to forage, hunt, buy, barter, or trade for it. Or worse. Hunger strips away the resolve

Figure 5:

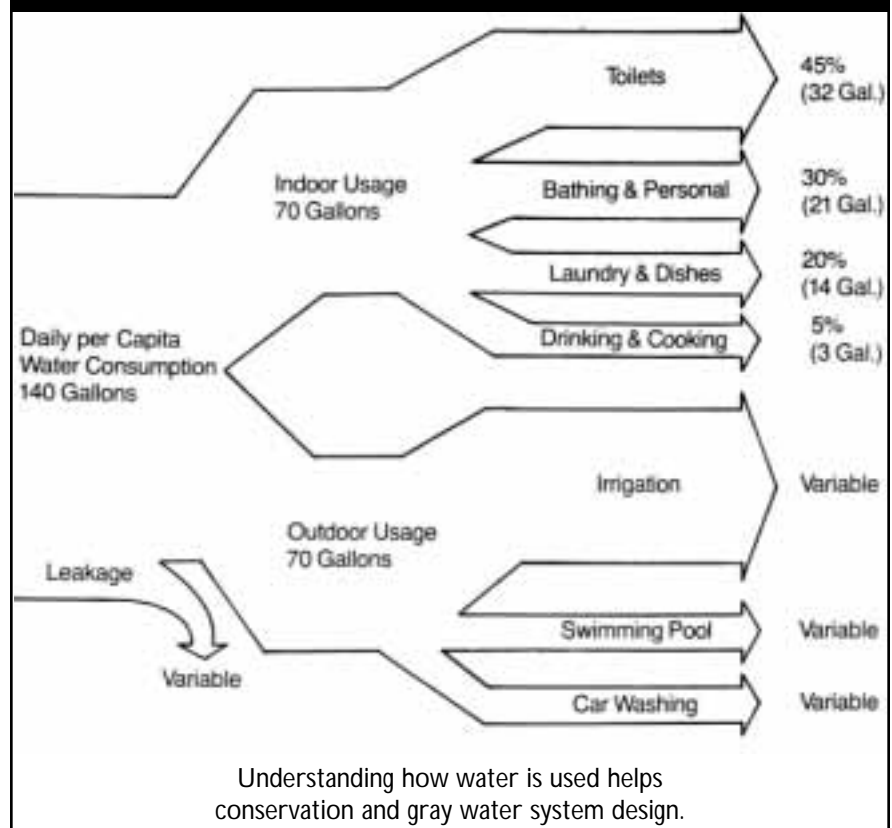



of people unaccustomed to its grip. Foodstuffs in most cities would disappear in a few days during a real crisis.

**Preparation:**

As one becomes more self-reliant, there is less dependence on (or need to buy) water, electricity, food, and fuels. Transportation needs also decline, allowing you more time to live and work at home. Coincidentally, this process prepares oneself for short and long-term disasters.

Here are some additional thoughts on preparations for water, food, energy, heat, lighting, motors, electronics, communication, and transportation.

**Water:** In a crisis, life is water. If your shelter—home, building, garage, cabin, RV, camper, tent, tipi, tarp, or cave—is connected to the town or city supply, your backup plan is to fill everything you can as soon as you can. If you can't develop your own source, prepare some way to store water in 5-55 gallon plastic containers, or plastic, wood, or steel tanks.

If you plan to develop a water source, or already have, make certain that your system is not completely dependent on utility or generator power. The process of water usage can be broken down into four areas: extraction, transport, storage, and pressurization (Fig. 3). Treat them as separate issues to maximize the versatility of the system. A low-yield water source quickly accumulates enough water to handle a standard household (Fig. 4).

There are low-power, low-voltage, and energy-efficient alternatives to the standard submersible pump. These can be piggybacked onto existing systems or work alone. PV modules powering a 12V or 24V pump (no battery) have seriously challenged wind-powered pumps in unattended operation, like livestock watering, in the past decade. Most renewable energy systems use something similar.

Water you waste also wastes the energy invested to get the water to



This design of solar water heater exposes the tanks directly to the sun in an insulated box.

you. A more active conservation method makes multiple use of the water. A “gray-water” system often doubles the usefulness of the water supply (Fig 5). Cooking, drinking and rinsing are the purest uses. Garden, clothes washing, and toilet are secondary uses. A plan and a bit of plumbing will help with this. There are several books on gray-water systems.

Look at rainfall collection, cisterns, and pools as additional sources and storage methods.

**Food:** Food is one of the first concerns anyone will have in a crisis. Food issues revolve around supply, preservation, and cooking.

1. Supply is what you start with, if you don't grow your own. A stockpile, however small, is a good idea. Trading work or goods with people who farm and garden also works.

A growing space and some seed are the best investment. Learn what to do with the seeds, and how and when to use them. Greenhouses and growframes provide vital protection against the elements, insects, and foraging animals and otherwise assist with year-round growing.

2. Preservation recognizes that food must be preserved against spoilage and infestation. Standard refrigerators and freezers work when there is abundant electricity. In an RE system, they hog energy. A high-efficiency, low-voltage refrigerator is expensive, yet rugged. More importantly, it frees up an appreciable chunk of energy that would be otherwise generated, stored, and inverted—only to be wasted. There are alternatives to refrigerators—canning and dehydrating, selective harvesting, and earth storage (i.e., a root cellar). Several good designs of solar dehydrators exist. Using one or more of these techniques further reduces the load on, or the need for, a refrigerator.

3. Cooking. It takes energy to cook food, particularly grains and vegetables. How much? Of what type? Solar cookers are a good bet if you're home. A 24-hour solar-powered oven is possible. A parabolic tray of less than 100 square feet can heat natural oils in excess of 350 degrees F. (100 degrees F short of their flash point) and store a sufficient quantity to keep the oven of uniform temperature throughout a 24-hour period. Use gas or wood heat to back up this system.



**Energy:** Your home is probably supplied with energy in the form of electricity and natural gas. Rural homes may use wood energy and propane. These energy “sources” are converted into only a few useful forms: heat, light, mechanical motion, and sound (stereo and radio).

**Heat:** Heat is a cherished form of energy and the biggest load in the home. Space heating. Water heating. Cooking. Dishwashing. Clotheswashing. Both refrigerators and air conditioners are heat pumps.

Good designs of solar collectors exist to handle these heating tasks. While designing a home to use solar energy is optimal, many homes can be retrofitted to use it effectively. Thermal mass—water, concrete and rock—will store solar energy for nighttime and storms. Save wood and other fuels for really bad weather. The perceived need for air conditioning and massive heaters is a coverup for poor design, sloppy construction, and cheap materials. Good insulation is a must—floor, walls, and ceiling—to avoid heat loss in winter and heat gain in summer.

A good understanding of how heat moves (radiated, conducted, and convected) and what happens to radiated heat (transmitted, absorbed, and reflected) helps collect, contain, store, use, and release it.

**Lighting:** Lighting is essential for moving about at night, or in dark places. Still, night is for sleep, even in emergencies. Rest is important in survival. And sleeping saves light!

Incandescents, fluorescents, LEDs, and oil lamps all have value in lighting.

1. Incandescents, like standard household 120V bulbs and spotlights, gobble energy. Reserve their use to short durations. 12V automotive (turn signal type incandescent) bulbs are inexpensive, work directly on 12VDC, and are low-wattage. Still, use them sparingly.



This electric motorcycle is recharged daily from two solar modules.

2. Fluorescents, particularly those that are high-frequency (20KHz or above) are efficient and long lived.

3. LEDs are light-emitting diodes that operate at extremely low power. LEDs may be grouped together to increase voltage and light intensity. They're expensive but have a service life hundreds of times longer than incandescents.

4. Oil lamps will burn natural oils that may be pressed from many types of plants.

**Motors:** Motors convert electricity into mechanical motion. Motors power appliances in the home and tools in the shop. Pumps, fans, hair dryers, coffee grinders, juicers, turntables, tape decks, CD players, vacuum cleaners, computers, answering machines, and electric can openers use AC or DC motors.

High-wattage motors are difficult to power with low-voltage DC directly. Use an inverter or generator, as needed. Low-voltage DC motors may be substituted for AC ones under 2 HP. Or seek their 12V DC counterparts. Of course, manual tools don't need electricity to work.

**Electronics:** Electronic devices may be divided into two categories: high voltage and low voltage. The bigger and heavier the electronics, the more likely the need for 120V, 60-cycle AC. This includes the family stereo system, computers and peripherals, printers, television, and microwave ovens. Inverters and generators will be needed to power these units.

Light-duty electronics work around low-voltage DC, often below 12V. This includes remote phones, answering machines, portable radios, calculators, and portable CD and tape players. Look for a black module that plugs into the wall receptacle. The other end plugs into a DC input jack. DC input jacks may also be found on battery-powered units.

With a suitable DC-DC converter (or a dropping resistor), these electronic gizmos can be directly powered from a 12V car battery. (With a small modification, the jack can be re-wired to also recharge NiCads while they're in the radio.) Note the voltage printed near the jack to find the unit's voltage. Or count the number of cells (batteries) the unit contains and multiply by 1.5V to calculate the voltage. Or read the rating on the black module that plugs into the wall. This will help select the dropping resistor or converter setting.

Most electronic devices are polarity sensitive. By law, manufacturers are required to show the polarity of DC inputs, usually with a symbol. Wire the jacks and plugs accordingly.

Small 12V B&W TV sets may also prove handy, providing local coverage of a crisis. (Sorry, 12V color TVs gobble energy. Avoid using them.) These and other 12V devices often use a cigarette lighter plug (like the one that plugs into the car dash). If your vehicle doesn't have one, buy a lighter receptacle from an RV or renewables dealer. It can be clamped to the car battery posts or hardwired into the vehicle.

**Communication:** Details of what is happening beyond your own influence

during a crisis is useful and, perhaps, crucial. In a blackout, the AM-FM radio in a car or truck may be the only communication at your disposal. At low volume, a radio will work for many days on just the car battery. You may need to position the vehicle (and antenna) away from buildings to get good reception. The news may not be reassuring if you're expecting help, but it will help you make better guesses or decisions about what you can and can't do.

Battery-powered, multi-band radios or boomboxes that use dry cells are equally good. With rechargeable cells (i.e., with NiCads) installed, there is no end to their useful service life. The cells can be recharged from renewable energy sources or even the 12V battery in a car. Note the actual voltage, use a converter or dropping resistor, and observe polarity. At low volume (or with earphones), these radios use only a tiny amount of energy in operation.

Transceivers, ham radio sets, walkie talkies, and CB (Citizen Band) radios are all useful, particularly for communities. Understand the power requirements to ensure that you can meet them. As well, recognize that sophisticated radio gear doesn't mean more effective communication. The semiconductor junctions in transistors and chips are extremely vulnerable to EMP (electromagnetic pulses) generated at high altitudes by both nuclear weapons and meteor strikes. The more complex something is, the more there is that can go wrong with it.

**Transportation:** Transportation may be adversely affected by crisis. Roads blocked with debris or other vehicles, bridges out, power lines down—these are common themes in a disaster. Owning a 4WD vehicle helps but it will need fuel, oil, tires, and parts to operate.

Vehicles converted to electric propulsion have an advantage over gas engines. There are only a few sources for gasoline. An electric vehicle (EV)

is "fueled" by electricity from utility power, a standby generator, and renewable energy systems (solar, wind, or hydro). An EV has an additional advantage over vehicles with engines: it is silent in operation.

It may be easier to get around with motorcycles (noisy unless electric) and bicycles (mountain-type). Closer to home, carts, wagons, wheelbarrows, and garden carts will help with everyday work or emergencies. Again, with self-reliance, there is simply less need for transportation.

(Photos and drawings in this article came from these books by Michael Hackleman:

• Wind and Windspinners: A Nuts' & Bolts' Guide to Wind-Electric Systems

• The Homebuilt Wind-Generated Electricity Handbook

• Better Use Of: Lights, Appliances, Shop Tools, and Other Electric Loads

• At Home with Alternative Energy

• WaterWorks: An Owner Builder Guide to Rural Water Systems

• The New Electric Vehicles: A Clean and Quiet Revolution

For a publication list, send an SASE to Michael Hackleman, PO Box 327, Willits, CA 95490. Δ

## No Electricity? No Problem!



Designed to withstand hot temperatures

### GAS REFRIGERATORS

- 13.3 cubic feet
- Textured almond or white molded steel cabinet
- Reversible doors
- Single deep crisper
- Two deep-door, shelved
- Mounted on heavy duty rollers
- LP or natural gas
- Thermostat controlled
- Front push button ignitor

Weight: 190 lbs.

Dimensions: 60"H x 32"D x 28" W

**1-800-898-0552**

\* Also lowest prices on Norcold \*

## It ain't cold if it ain't *Crystal Cold*



For more information contact:  
Ervin's Cabinet Shop  
220 North County Road 425 E.  
Arcola, Illinois 61910